

Electro-Hyd. Circuit - JumboZ-300E PTO with Power Helm

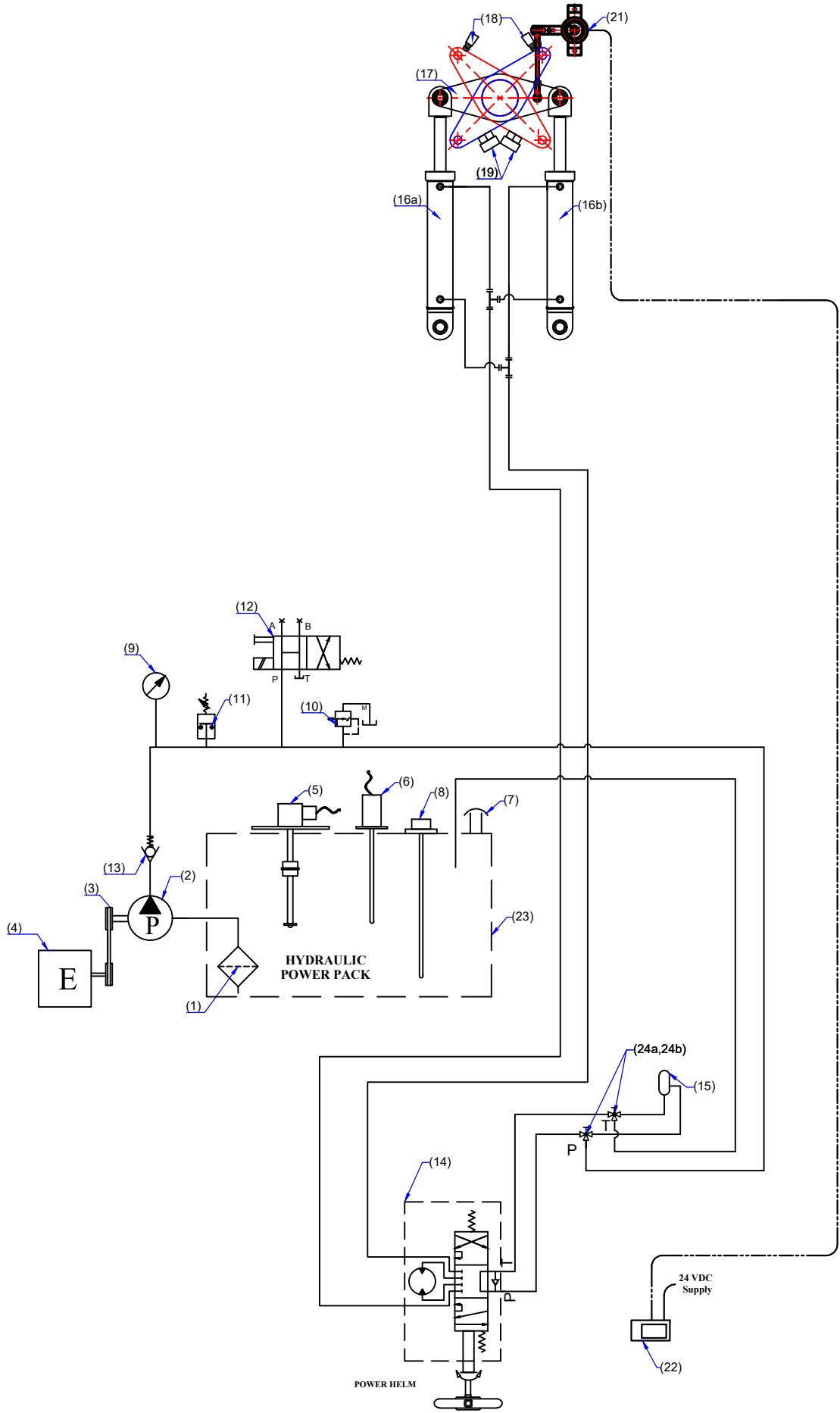

**MAC ♦ N ♦ HOM SYSTEMS
KOCHI - 20**

DESIGNATION

Electro-Hydro. Circuit of JumboZ-300E
PTO -Power Helm

DWG. No.

MHS-1831
Page 1 of 2

DATE

11.04.2023

A

B

C

D

E

F

G

H

Electro-Hyd. Circuit - JumboZ-300E PTO Power Helm

SI No.	Description
1	Suction Strainer
2	Hydraulic pump
3	PTO Pulley
4	Engine
5	Oil Level Sensor
6	Oil Temp. Sensor
7	Filler Breather
8	Oil Dip Stick
9	Pressure Gauge
10	Pr.Relief Valve
11	Pre.Switch.Low Pre.Alarm
12	Unloading Valve
13	Non-Return Valve
14	Power Helm Pump
15	Flanged Reservoir
16a,16b	Hyd. Actuator - JumboZ 300
17	Tiller Arm
18	Limit Switch
19	Mechanical Stopper- (Yard Supply)
20	Oil Reservoir
21	Rudder Angle Sensor
22	Rudder Angle Indicator
23	Power pack Tank
24a,24b	3 Way Ball Valve



**MAC ♦ N ♦ HOM SYSTEMS
KOCHI - 20**

DESIGNATION

Electro-Hydro. Circuit of JumboZ-300E
PTO -Power Helm

DWG. No.

MHS-1831
Page 2 of 2

DATE

11.04.2023

A

B

C

D

E

F

G

H